

The DuPont Performance Polymers Laboratory (Elastomers)

DuPont Performance Polymers Conference

May 20th, 2010

Albergo Cocca Hotel

Sarnico (Bg)



The miracles of science™

Patrick Paglia

European Technical Center



- ❑ Outskirt of Geneva
- ❑ 250 people
- ❑ DPP - Elastomers lab : 22 people
- ❑ Technical Support to customers located in Europe & abroad
- ❑ Vamac®, Viton®, Kalrez®, Viton® Free Flow, Neoprene
- ❑ ISO/TS 16949:2009 (Viton®) & ISO 9001:2008 (all products)
- ❑ Yearly Compounder Course – next June 2010

What's unique to ETC

- ❑ Many professionals with multiproduct experience
- ❑ Broadest range of diversity and language skills
- ❑ Central geographical location / time zone
- ❑ Well integrated with the business
- ❑ Well integrated & synergies with DuPont labs

DPP definition of TS&D Lead Center

- ❑ A TS&D LAB with unique or clearly differentiated capabilities within DPE, serving a strategic technology segment
- ❑ Critical mass (staffing, investment, competencies) to provide full service for that technology or market segment world wide
- ❑ Close links and exchanges with other leading, non-competing players active in the same value chain for the technology (for example, mould manufacturers)
- ❑ Ideally geographically close to the main markets
- ❑ Provides support to the other regions

Elastomers lab of the European Technical Center

- ❑ Several mills – four (0.5 kg to 15 kg)
- ❑ Internal mixer – two (1.6 liter & 9 liter)
- ❑ Presses for slabs
- ❑ Mooney, MDR, RPA, MTS, Goettfert, Rosand capillary
- ❑ + standard testing equipment (Tensile, TR 10, etc.)
- ❑ Injection moulding machines – three
- ❑ 2K injection moulding machine
- ❑ Oven for post-cure & aging
- ❑ Explosive Decompression Unit
- ❑ Strong analytical capabilities

Injection moulding capability

- ❑ One vertical & two horizontal injection moulding machines
- ❑ Product development beyond conventional rubber lab equipments (RPA, capillary rheometer, etc...)



- ❑ Optimisation of custom compounds – flow & release

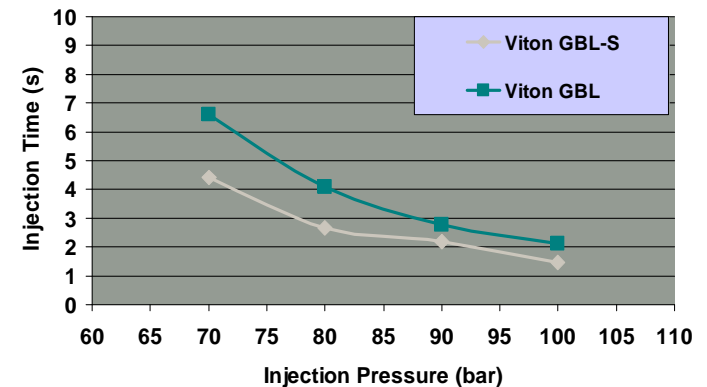

- ❑ MIR, 135 tons
- ❑ 38 mm barrel
- ❑ Reciprocating screw
- ❑ Essentially o-ring moulds of various part dimensions & surface finishes

Injection moulding capability

□ New entry :

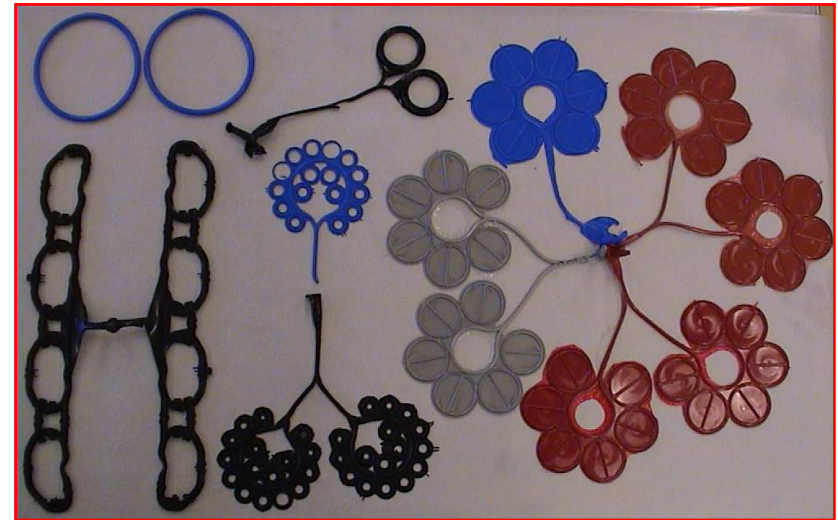

- To cope with broader DPP portfolio
- Maplan, 300 tons
- 27 mm barrel, L/D 13
- Ideal for low volume compounds, e.g. evaluation of experimental polymers
- Quick cleaning for transitions

- O-ring moulds
- Diversification of mould estate :
 - Multiple cavity moulds for broad processing assessments in one go : flow, release, scorch
- Special projects : brush for long runs

Injection moulding capability

- ❑ Vertical injection moulding machine
- ❑ REP, 70 tons
- ❑ Bonded parts



2K injection moulding capability



Rotary table

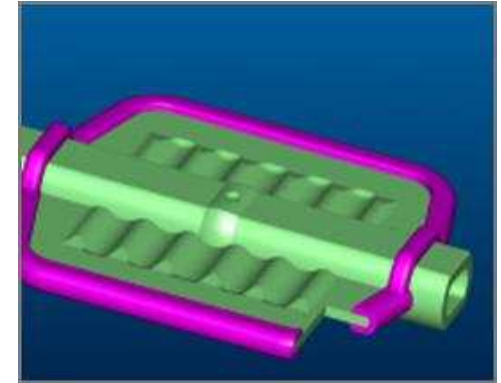

Peel sample



Zytel® FE 270056
Vamac® Ultra IP

Optimum process parameters

<u>Vamac® cavity:</u>	190°C
<u>Curing time:</u>	45 sec
<u>Post cure:</u>	40min @ 190°C
<u>Total cycle time:</u>	70 sec

Hardness, Shore A:	60
Compression set:	~20 %
Peel adhesion:	>2.5 N/mm

Compression moulding capability



- ❑ Characterisation of new product
- ❑ Determination of best releasing aid package
- ❑ Optimisation of custom compound with emphasis on release performance
- ❑ Complementary to the injection moulding assets

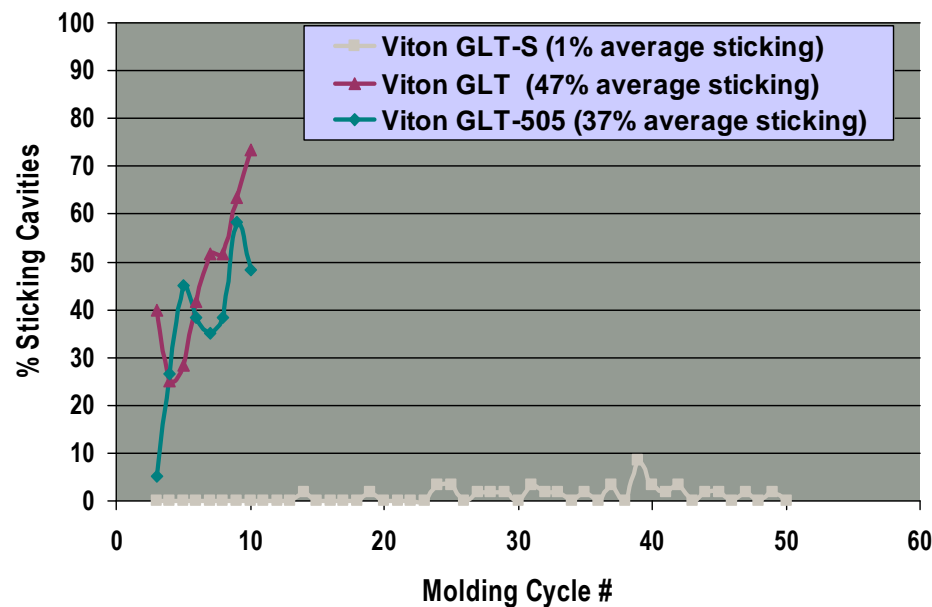

ED testing equipment



Uncompressed
(smaller piece)

To be compressed
(larger piece)

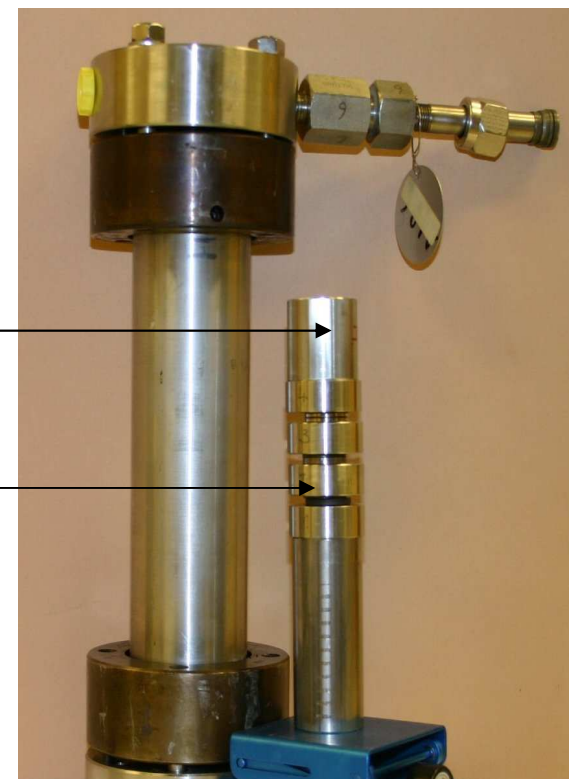

A program developed internally ensures constant data acquisition and optimum pressure release

ED testing equipment

- 100 % CO₂
- 24 hour exposure
- Temperature : Room Temperature, 100 °C, 150 °C, 200 °C
- Pressure : 5 MPa, 10 MPa, 15 MPa
- Decompression rate : 2 to 12 MPa/min
- One decompression cycle
- Uncompressed and compressed K-325 o-rings (37.47 mm x 5.33 mm, 3 specimen per condition)
- Samples analyzed based on Norsok M-710a visual inspection method

Analytical laboratory

THERMAL ANALYSIS

- Differential Scanning Calorimeter (D.S.C.)
- Thermo Gravimetric Analyzer (T.G.A.)
- Thermo Mechanical Analyzer (T.M.A.)

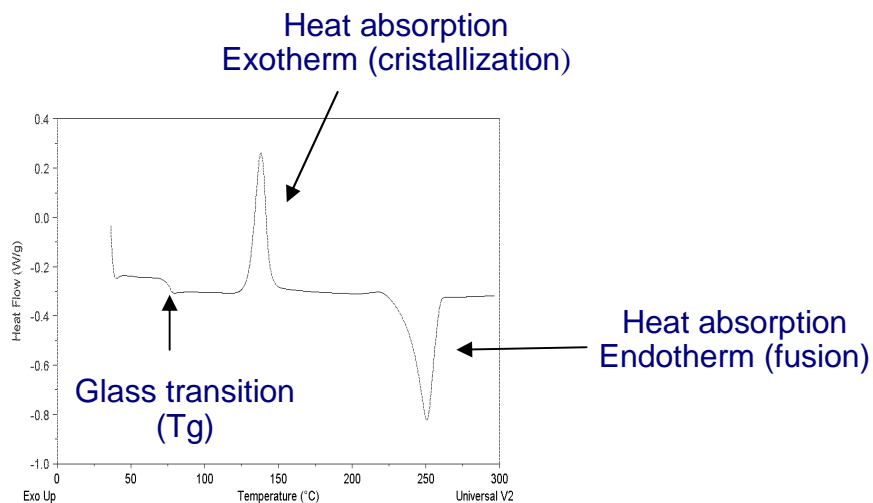

D.S.C

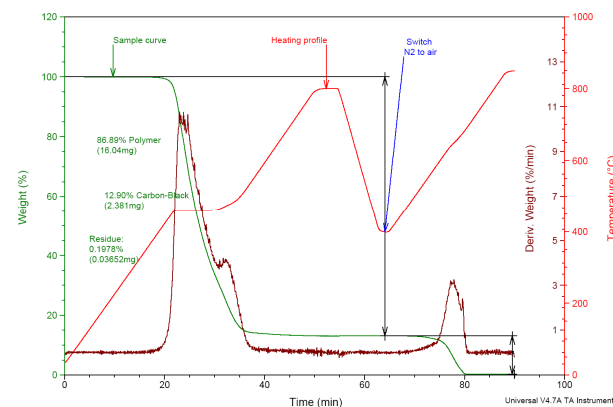

T.G.A

Analytical laboratory

□ SPECTROMETRIC ANALYSIS

□ Fourier Transformed Infra-Red Spectrometer (F.T.I.R.)

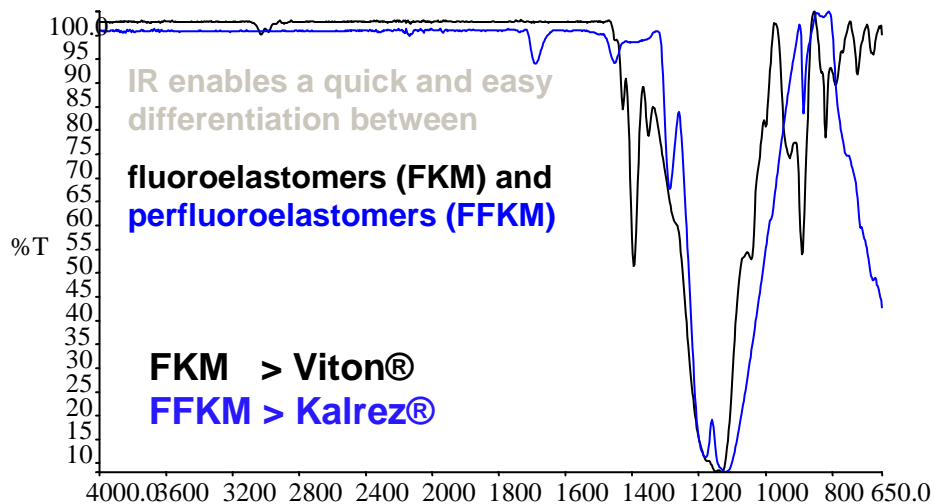

□ X-Ray Fluorescence Spectrometer (X.R.F.)

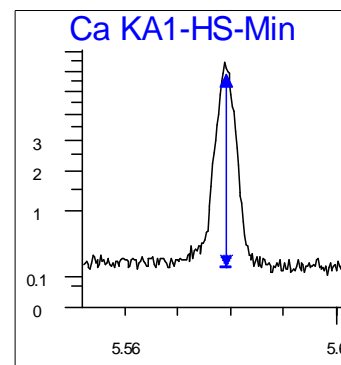
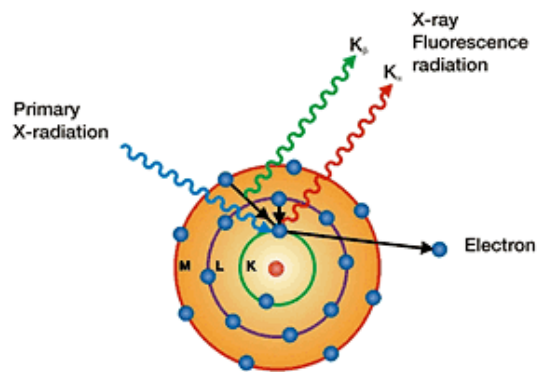

Analytical laboratory

- ❑ OPTICAL BINOCULAR & IMAGING
- ❑ ANALYTICAL FACILITIES FROM OTHER DUPONT DIVISIONS
- ❑ COMPLEMENTARY SUPPORT FROM RESEARCH INSTITUTE

Akron extrusion layout



Barrier screw used for optimal FKM extrusion

- Product / compound development
- VTR-7551 for thin veneers
- Bonding evaluation of Viton-silicone hoses for turbo charger & industrial applications

Akron multi-extrusion layout

Tandem Extruded hose

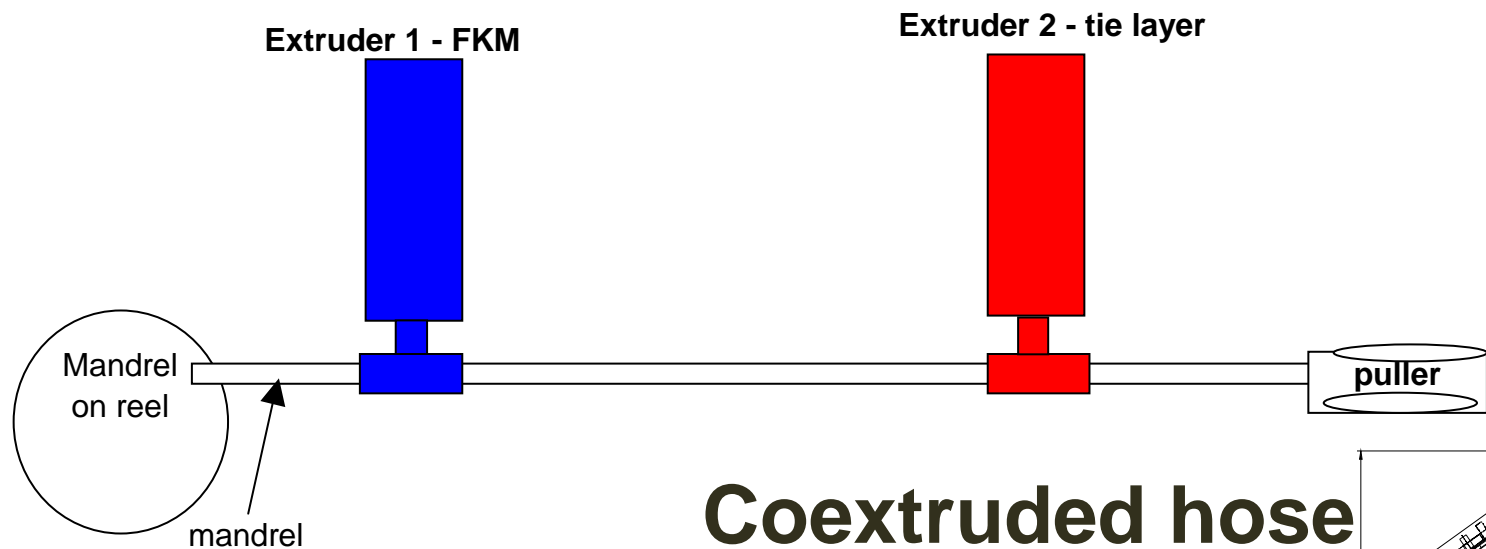

Coextruded hose

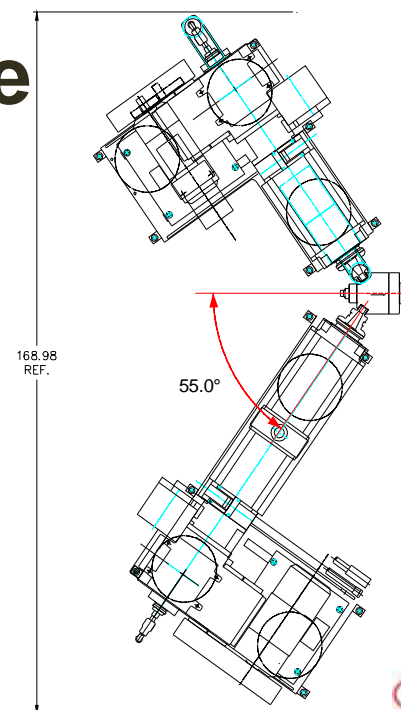
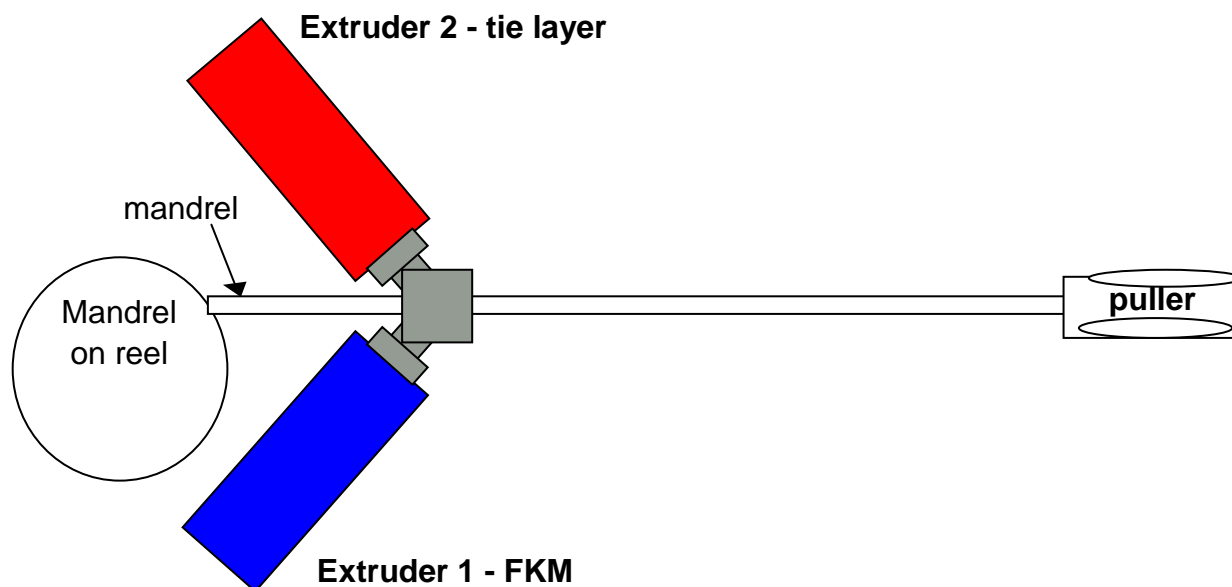

The information set forth herein is furnished free of charge and is based on technical data that DuPont believes to be reliable and falls within the normal range of properties. It is intended for use by persons having technical skill, at their own discretion and risk. This data should not be used to establish specification limits nor used alone as the basis of design. Handling precaution information is given with the understanding that those using it will satisfy themselves that their particular conditions of use present no health or safety hazards. Since conditions of product use and disposal are outside our control, we make no warranties, express or implied, and assume no liability in connection with any use of this information. As with any product, evaluation under end-use conditions prior to specification is essential. Nothing herein is to be taken as a license to operate or a recommendation to infringe on patents.

Caution: *Do not use in medical applications involving permanent implantation in the human body. For other medical applications, discuss with your DuPont customer service representative and read Medical Caution Statement H-50103-3.*

Copyright© 2010 DuPont™. The DuPont Oval logo, DuPont™, The miracles of science™, DuPont™ Viton® are registered trademarks of E.I. du Pont de Nemours or its affiliates. All rights reserved.

